

ТЕХНИКА ҒЫЛЫМДАРЫ
ТЕХНИЧЕСКИЕ НАУКИ
TECHNICAL SCIENCES

МРПТИ 44.29.39
УДК 620.92

SMALL POWER GENERATION: THE PATH TO SUSTAINABLE ENERGY
SUPPLY

SHERYAZOV S.K.¹ , ZHUBANDYKOVA Zh.U² , KAINENOVA T.S^{2*} ,
YERKEN A.A² 

Sheryazov Saken Koishybaevich¹ — Doctor of Technical Sciences, Professor, South- Ural State Agrarian University, Chelyabinsk, Russia

E-mail: sakenu@yandex.ru, <https://orcid.org/0000-0001-8795-5114>;

Zhubandykova Zheniskul Umirtaevna² — Candidate of Technical Sciences, Associate Professor (ARU), Aktobe Regional University named after K. Zhubanov, Aktobe, Kazakhstan.

E-mail: tima2001@inbox.ru, <https://orcid.org/0000-0003-2028-9262>;

***Kainenova Tursyngul Sansyzbaevna**² — Master of Pedagogy and Psychology, senior Lecturer, Aktobe Regional University named after K. Zhubanov, Aktobe, Kazakhstan.

E-mail: kaynenova83@mail.ru, <https://orcid.org/0000-0001-8750-5703>;

Yerken Abylai Almazuly² — Master's student of the ARU named after to K. Zhubanova, Aktobe, Kazakhstan.

E-mail: Abylai.erken@mail.ru, <https://orcid.org/0009-0001-4537-8942>;

Abstract. In the modern world, electricity has become a vital resource that ensures the functioning of almost all aspects of our daily lives. However, despite the rapid development of technology and infrastructure, power supply networks are increasingly facing challenges such as power shortages and congestion. This is where an innovative idea comes on the scene that could change the way we meet our electricity needs. We are talking about the concept of "automatic small-scale power generation" - an intelligent system that automatically activates small power plants located close to end users in the event of a power shortage in the main grid. This is not only a way to increase the reliability of electricity supply, but also to make it more stable and affordable.

The purpose of this study is to study and analyze the potential of small-scale power generation to improve the sustainability of energy supply, especially in regions with a power shortage, and to determine the best strategies for integrating such systems into the existing power grid with minimal losses and maximum efficiency. The situation in the industry is becoming increasingly difficult due to the growth of small generation capacities, which are changing the nature of electricity production.

Key words: Electric power, power plant, content analysis, statistical analysis, comparative analysis, relay protection.

Introduction. One of the key issues facing the deployment of small-scale electricity generation is its successful integration into the existing electricity grid. This is an important link in the transition to a more sustainable and efficient energy system. Optimal integration of small-scale generation allows you to minimize energy losses and maximize overall efficiency.

Coordination between small generators and grid operators is also an important aspect of integration. Effective coordination between these parties allows you to manage the distribution of energy and ensure the stability of the network.

The topic of small-scale power generation is highly important and brings a number of significant advantages:

Reducing dependence on large centralized power plants - Traditional power plants, such as coal-fired and nuclear power plants, are often characterized by a high degree of centralization and monopoly. This can create vulnerabilities in the event of accidents, technical failures, or even terrorist attacks, which can lead to massive power outages.

Minimizing the risk of power outages - Small-scale generation contributes to the creation of a

decentralized energy infrastructure. This means that in the event of problems or accidents at one of the small generation systems, the other systems remain active and can continue to supply electricity.

Decentralization in regions with a power shortage - In regions where there is a power shortage and power outages are frequent, small-scale generation can be a lifesaving alternative.

The key problem that should be considered within the framework of this study is the development and implementation of strategies and technologies for small-scale power generation to increase the level of energy independence and stability of energy supply in the city of Aktobe[1].

Material and research methodology. The following methods were used in the course of the work: content analysis, statistical analysis, comparative analysis, expert survey.

An analysis was conducted on the operations in the field of electricity generation and supply in regions facing power shortages and high dependency on external sources. Additionally, data analysis was carried out using information obtained from 'KEGOC' (Kazakhstan Electricity Grid Operating Company) and the Joint-Stock Company 'Kazakhstan Power Grid Operating Company'.

An analysis was undertaken to examine the experiences of foreign countries in addressing issues specific to regional power systems, employing a method of comparative analysis. Specifically, the adaptive utilization of several examples in Russia was scrutinized.

An expert survey enabled the identification of key issues, opinions, and suggestions from specialists in this field, serving as the foundation for formulating proposals to address them [2].

Splitting the generators of small power plants into a local load with minimal latency in case of failures in the external network.

Relevance of small-scale power generation research in the modern electric power industry. The situation in the industry is becoming increasingly difficult due to the growth of small generation capacities, which are changing the nature of electricity production. These capacities, although they make up a relatively small part of the installed capacity, play a key role in providing electricity in regions with a shortage.

Figure 1 shows a generalized structural diagram of a power system with large centralized, small distributed power plants.

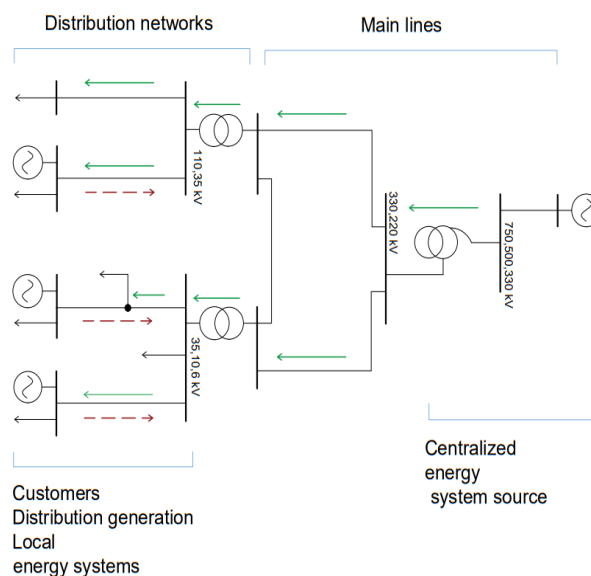

Figure 1. Generalized Block Diagram of Electric Power System with Distributed Generation.

In the context of partial decentralization of industrial capacities, the electric power system acquires new characteristics:

1. The traditional mechanism of "production, transmission, distribution, consumption" of electricity is changing: energy production, including decentralized production, is beginning to be carried out near end consumers;

2. Large distributed energy can be represented both by individual power plants connected at the level of distribution networks and by entire areas of the distribution network with small power plants of various types, local power systems or so-called microgrids [3,4].

The variety of generation technologies used is growing. Gas turbine and gas piston units are widely used, and renewable generation technologies (wind, solar energy, etc.) are being developed. At the same time, it should be noted that the units of small power plants have a number of features that differ from the sources of large power plants and affect their behavior in static and dynamic modes: piston units and gas turbine units are power turbines, the stochastic nature of electricity generation, the wide use of switching circuits through inverters and frequency converters [5].

With regard to electric power systems containing small distributed power plants, it seems appropriate to distinguish the following levels of relay protection and protection (Figure 2):

- ARP (Automatic relay protection) external network;
- ARP subnets;
- Long-term protection and automation (LtPA).

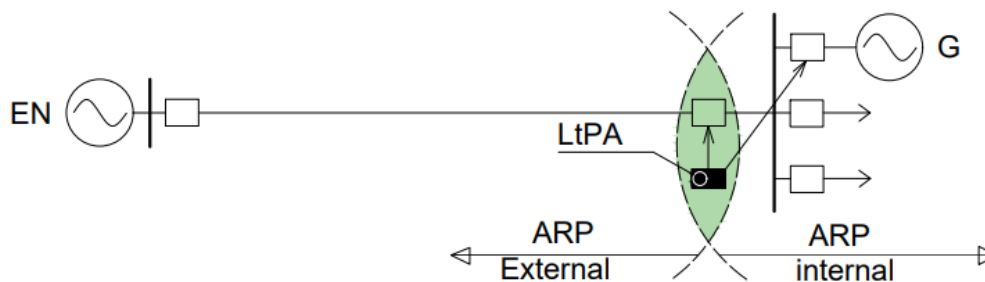

Figure 2. Relay Protection Levels in an Electric Power System with Small Power Plants.

The power plants are designed to ensure the proper operation of small power plants and prevent their possible negative impact on electrical modes and the operation of external network relay protection and automation devices. As a rule, the operation of the power supply system is considered in case of system failures, modes of loss of connection with the network of the external electrical system, external short circuits. It should be noted that in the implementation of small power plants, the issues of creating LtPA are of great importance, including due to the fact that relay protection and protection systems of the adjacent network are designed, as a rule, without taking into account the possibility of its occurrence. Power plants in the distribution network, even when improvement measures are implemented, cannot fully solve all the problems of managing distributed generation during failures and emergencies [6,7].

The above-mentioned approaches and the corresponding requirements from the point of view of the organization of relay protection are of a conceptual nature and, of course, require clarification and addition. For typical typical situations, it seems expedient to draw up and structure a set of relay protection requirements and formalize them in the form of a regulatory document. Structural requirements should be met taking into account the following factors:

- Type and capacity of connected power plants, total share of power plants in the electric area;
- Voltage class, diagram and characteristics of the neighboring network.

It is worth noting that today the share of small power plants in the energy system is small, and these power plants are mainly owned by industrial enterprises, so the regulatory documents should pay special attention to the requirements for the power plant, while making decisions on implementation. RPA for power plant generators and the internal grid can still be solved at the

discretion of the plant owners in most cases [8].

Results and discussion of it. Analysis of load data for each hour of the day on the longest day of the year on June 15 and the shortest on December 21, 2022 shows that peak electricity consumption is usually at 19:00, reaching 892 MW, while the minimum consumption is observed at 6:00 and is 788 MW. This fluctuation in electricity consumption can overload the power grid, especially during peak hour [9].

In most cases, an electric power system with small power plants is characterized by the accumulation of operating currents and short-circuit currents. The reason for this may be a decrease in the current component from the external network in the event of a fault at nearby sites or in the event of a short circuit through transient barriers: in addition, the short-circuit currents of small power plants may correspond to the currents in the pre-fault mode. For the example under consideration (Figure 3), the areas of location of operating mode currents and fault currents in the complex plane are shown [10].

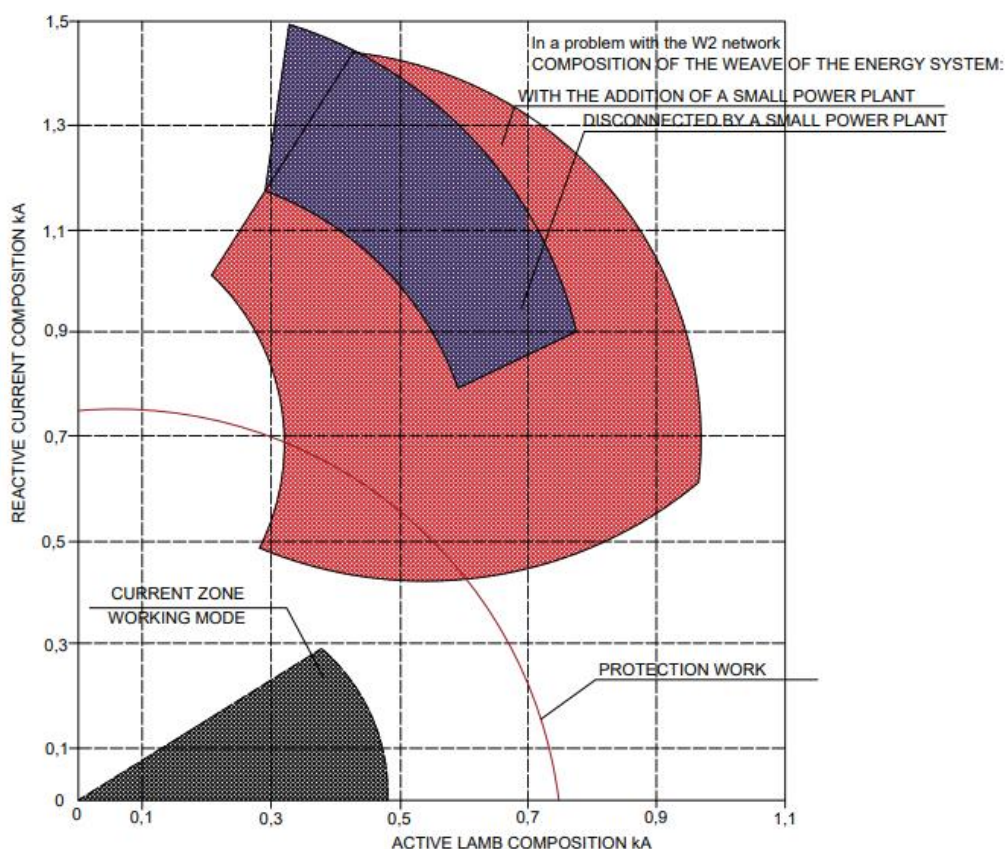

Figure 3. Areas of currents of operating and emergency modes when connecting to a "weak" 35 kV distribution network of a mini-power plant with a capacity of 16 MVt.

Must provide sufficient sensitivity to external influences; act in the first place to shut down the generators of a small power plant with a regulated time delay from the moment of operation of its own protection or technological automation; as well as perform the functions of non-selective protection of high-level elements on the part of the Small Power Plant [11].

The following starting elements can be added to the LtPA: voltage decrease, increase, frequency decrease, increase, as well as those that respond to zero circuit voltage, negative circuit voltage, and current.

In table 1 shows an example of establishing the composition and operating parameters of the functions of the LtPA, formed on the basis of the study of the experience of a number of foreign countries [12,13].

Table 1.

An example of the composition of functions and operating parameters for LtPA.

$U <$	$U >$	$f >$	$f >$	$I_2 >$	$\frac{df}{dt} >$
$< 0,6U_{\text{НОМ}}$ $0,05 \text{ s}$	$\geq 1,5U_{\text{НОМ}}$	47-59	51-52	$(0,05 - 0,2) I_{\text{НОМ}}$	$\geq 2,5$
$(0,6 - 0,8)U_{\text{НОМ}}$ $\geq 0,5 \text{ s}$	0,1-1	0,3 - 0,5	0,3-0,5	0,1-10	$\geq 0,1$

Conclusion. In today's world, electricity plays a key role in sustaining our daily lives and economies. However, as electricity consumption increases, power grids face increasing demands, especially during peak hours. This can overload the grid and eventually cause a power outage.

Thus, the key problem that should be considered within the framework of this study is the development and implementation of strategies and technologies for small-scale power generation to increase the level of energy independence and stability of energy supply in the city of Aktobe.

The task of developing algorithms that ensure the adaptation of the response time of the LtPA to the parameters of the current mode is urgent.

The implementation of the third approach requires the improvement of emergency automation in the distribution network, taking into account its topology and the features of the previously described transient processes; In particular, Equipment Overload Limitation (AOPO) – Automatic Equipment Overload Limitation, Automatic Voltage Reduction Limitation – AOSN) – is a study of technical solutions to limit automatic voltage reduction and it is worth paying attention to the development. The task of identifying and eliminating asynchronous modes in the distribution network (in particular, with several small power plants) is becoming relevant.

References

1. Myshkina, L.S. (2017). Distributed generation is a means of increasing power system survivability // Novosibirsk State Technical University, Novosibirsk, Russia. Vol. 19, 23-30. DOI: <https://www.energyret.ru/jour/article/view/336/295>
2. Pepermans G., Driesen J., Haeseldonckx D., Belmans R., D'haeseleer W.. (2005). Distributed generation: definition, benefits and issues, Energy Policy, Vol. 33, 787-798. DOI: <http://dx.doi.org/10.1016/j.enpol.2003.10.004>
3. Nudel'man G., Onisova O. (2014). Relejnaya zashchita i avtomatika v usloviyah razvitiya maloj raspredelyonnoj energetiki. Elektroenergiya. Peredacha i raspredelenie. Vol. 4, 106-114. DOI: <https://rucont.ru/efd/500220> .
4. Grabovskij, V. P.(2019). Analiz povrezhdaemosti valoprovoda turboagregata pri nesinhronnom vklyuchenii generatora v set'.Voprosy tekhnicheskikh i fiziko-matematicheskikh nauk v svete sovremennyh issledovaniy [sbornik statej po materialam XVIII-XIX mezhdunarodnoj nauchno-prakticheskoy konferencii]. Novosibirsk: Associaciya nauchnyh sotrudnikov "Sibirskaya akademicheskaya kniga. Vol. 8-9, 43-50.
5. Edvard C. (2020). Protection coordination practices distribution systems distributed generation.DOI:<https://electrical-engineering-portal.com/protection-coordination-practices-distribution-systems-distributed-generation>
6. Sushko, A. A. (2022). Osnovnye vidy zashchit (relejnaya zashchita i avtomatika). Aktual'nye problemy obshchestva, ekonomiki i prava v kontekste global'nyh vyzovov[Sbornik materialov XII Mezhdunarodnoj nauchno-prakticheskoy konferencii]. Moskva: Obshchestvo s ogranichennoj otvetstvennost'yu "IROK". DOI: <https://www.elibrary.ru/item.asp?edn=whbxjq>
7. Lakervi E., Holmes, E.J. (2003) Electricity distribution network design 2nd edition. Published by Peter Peregrinus Ltd.,on behalf of the institution of Electrical Engineers,

London, United Kingdom Reprinted with revision.

8. Utverzhdenie Pravil ustrojstva elektroustanovok 20 marta 2015 goda (s izmeneniyami i dopolneniyami po sostoyaniyu na 3 yanvarya 2023 g.) <https://adilet.zan.kz/rus/docs/V1500010851>

9. Tishchenko, Y.N., Movsesova, N.S., Barybina, Y.G. (1990). Spravochnik po proektirovaniyu elektrosnabzheniya.

10. Kobzistyj, O. V., Noga, I. G. (2014). O raschete perekhodnyh processov v elektricheskikh setyah s nesimmetrichnym napryazheniem. Vol. 4, 281-285. DOI: <https://www.elibrary.ru/item.asp?edn=taotkh>

11. Pyushin, P. V., Nebera, A. A., Fedorov O. A. (2017). Perspektivy razvitiya i instrumenty avtomatizacii zadach ekspluatatsii ustrojstv RZA. Relejnaya zashchita i avtomatizaciya. Vol.2(27), 28-37.

12. Barkans, E. B. (2011). Zashchita ot razvalov i samovosstanovlenie energosistem. Relejnaya zashchita i avtomatizaciya. Vol. 4(5), 52-56. DOI: <https://srzau-ric.ru/izdatelskaia-deiatelnost/knigi/barkanc/>

13. ZAKON RESPUBLIKI KAZAHSTAN Ob energosberezhenii i povyshenii energoeffektivnosti (s izmeneniyami i dopolneniyami po sostoyaniyu na 29.09.2014 g.) https://online.zakon.kz/Document/?doc_id=31112351

Список литературы

1. L.S. Myshkina. Distributed generation is a means of increasing power system survivability.// Novosibirsk State Technical University, Novosibirsk, Russia. – 2017. – Vol. 19, 23-30. DOI: <https://www.energyret.ru/jour/article/view/336/295>

2. G. Pepermans, J. Driesen, D. Haeseldonckx, R. Belmans, W. D'haeseleer, Distributed generation: definition, benefits and issues, Energy Policy. – 2005. Vol. 33. – P. 787-798, DOI: <http://dx.doi.org/10.1016/j.enpol.2003.10.004>

3. Нудельман, Г. Релейная защита и автоматика в условиях развития малой распределённой энергетики / Г. Нудельман, О. Онисова // Электроэнергия. Передача и распределение. – 2014. – № 4(25). – С. 106-114. DOI: <https://rucont.ru/efd/500220>

4. Грабовский, В. П. Анализ повреждаемости валопровода турбоагрегата при несинхронном включении генератора в сеть / В. П. Грабовский // Вопросы технических и физико-математических наук в свете современных исследований: сборник статей по материалам XVIII-XIX международной научно-практической конференции, Новосибирск, 25 сентября 2019 года. Том 8-9 (15). – Новосибирск: Ассоциация научных сотрудников "Сибирская академическая книга". –2019. – С. 43-50.

5. C. Edvard. Protection coordination practices distribution systems distributed generation. – 2020. DOI: <https://electrical-engineering-portal.com/protection-coordination-practices-distribution-systems-distributed-generation>

6. Сушко, А. А. Основные виды защит (релейная защита и автоматика) / А. А. Сушко // Актуальные проблемы общества, экономики и права в контексте глобальных вызовов: Сборник материалов XII Международной научно-практической конференции, Москва. – 2022. DOI: <https://www.elibrary.ru/item.asp?edn=whbxjq>

7. E.Lakervi and E.J.Holmes. Electricity distribution network design 2nd edition. Published by Peter Peregrinus Ltd., on behalf of the institution of Electrical Engineers, London, United Kingdom Reprinted with revision, 2003.

8. Утверждение Правил устройства электроустановок 20 марта 2015 года (с изменениями и дополнениями по состоянию на 3 января 2023 г.). <https://adilet.zan.kz/rus/docs/V1500010851>

9. Ю.Н.Тищенко, Н.С. Мовсесова, Ю.Г.Барыбина. Справочник по проектированию электроснабжения, 1990.

10. Кобзистый, О. В. О расчете переходных процессов в электрических сетях с несимметричным напряжением / О. В. Кобзистый, И. Г. Нога // . – 2014. – № 4(9). – С. 281-285. DOI: <https://www.elibrary.ru/item.asp?edn=taotkh>
11. Илюшин, П. В. Перспективы развития и инструменты автоматизации задач эксплуатации устройств РЗА / П. В. Илюшин, А. А. Небера, О. А. Федоров // Релейная защита и автоматизация. – 2017. – № 2(27). – С. 28-37.
12. Барканс, Е. Б. Защита от развалов и самовосстановление энергосистем / Е. Б. Барканс // Релейная защита и автоматизация. – 2011. – № 4(5). – С. 52-56. DOI: <https://srzauric.ru/izdatelskaia-deiatelnost/knigi/barkanc/>
13. ЗАКОН РЕСПУБЛИКИ КАЗАХСТАН Об энергосбережении и повышении энергоэффективности (с изменениями и дополнениями по состоянию на 29.09.2014 г.). https://online.zakon.kz/Document/?doc_id=31112351

ШАҒЫН ЭЛЕКТР ЭНЕРГИЯСЫН ӨНДІРУ: ТҰРАҚТЫ ЭНЕРГИЯМЕН ҚАМТАМАСЫЗ ЕТУ ЖОЛЫ

ШЕРЬЯЗОВ С.К.¹ , ЖУБАНДЫКОВА Ж.У.² , КАЙНЕНОВА Т.С.^{2*} ,
ЕРКЕН А.А.² 

Шерьязов Сакен Койшыбаевич¹ — Техника ғылымдарының докторы, профессор, Оңтүстік-Орал мемлекеттік аграрлық университеті, Челябинск қ., Россия.

E-mail: sakenu@yandex.ru, <https://orcid.org/0000-0001-8795-5114>;

Жубандыкова Женискуль Умиртаевна² — Техника ғылымдарының кандидаты, доцент (АӨУ), Қ. Жұбанов атындағы Ақтөбе өңірлік университеті, Ақтөбе қ., Қазақстан.

E-mail: tima2001@inbox.ru, <https://orcid.org/0000-0003-2028-9262>;

***Кайменова Турсынгул Сансызбаевна**² — Магистр, аға оқытушы, Қ. Жұбанов атындағы Ақтөбе өңірлік университеті, Ақтөбе қ., Қазақстан.

E-mail: kaynenova83@mail.ru, <https://orcid.org/0000-0001-8750-5703>;

Еркен Абылай Алмазулы² — Магистрант, Қ. Жұбанов атындағы Ақтөбе өңірлік университеті, Ақтөбе қ., Қазақстан.

E-mail: Abylai.erken@mail.ru, <https://orcid.org/0009-0001-4537-8942>;

Аннотация. Қазіргі әлемде электр энергиясы күнделікті өміріміздің барлық дерлік аспектілерінің жұмыс істеуін қамтамасыз ететін өмірлік маңызды ресурсқа айналды. Дегенмен, технологиялар мен инфрақұрылымның қарқынды дамуына қарамастан, электрмен жабдықтау желілері электр қуатының жетіспеушілігі және кептеліс сияқты мәселелерге көбірек тап болуда. Дәл осы жерде біздің электр энергиясына деген қажеттіліктерімізді қанағаттандыру тәсілін өзгерте алатын инновациялық идея пайда болады. Біз "шағын көлемді электр энергиясын автоматты түрде өндіру" ұғымы туралы айтып отырмыз-негізгі желіде электр қуаты тапшылығы жағдайында соңғы тұтынушыларға жақын орналасқан шағын электр станцияларын автоматты түрде іске қосатын интеллектуалды жүйе. Бұл электрмен жабдықтаудың сенімділігін арттырудың ғана емес, сонымен қатар оны тұрақты және қолжетімді етудің бір жолы.

Бұл зерттеудің мақсаты-энергиямен жабдықтаудың тұрақтылығын арттыру үшін, әсіресе электр қуаты тапшылығы бар аймақтарда, шағын көлемді электр энергиясын өндірудің әлеуетін зерттеу және талдау және мұндай жүйелерді интеграциялаудың ең жақсы стратегияларын анықтау.минималды шығындармен және максималды тиімділікпен қолданыстағы электр желісіне. Өнеркәсіптегі жағдай электр энергиясын өндіру сипатын өзгертетін шағын генерациялау қуаттарының өсуіне байланысты күрделене түсуде.

Кілт сөздер: Электр энергетикасы, электр станциясы, контент-анализ, статистикалық талдау, салыстырмалы талдау, релелік қорғаныс.

МАЛАЯ ЭНЕРГЕТИКА: ПУТЬ К УСТОЙЧИВОМУ ЭНЕРГОСНАБЖЕНИЮ

ШЕРЬЯЗОВ С.К.¹ , ЖУБАНДЫКОВА Ж.У.² , КАЙНЕНОВА Т.С.^{2*} ,
ЕРКЕН А.А.² 

Шерьязов Сакен Койшыбаевич¹ — Доктор технических наук, профессор, Южно-Уральский государственный аграрный университет, г. Челябинск, Россия.

E-mail: sakenu@yandex.ru, <https://orcid.org/0000-0001-8795-5114>;

Жубандыкова Женискуль Умиртаевна² — кандидат технических наук, доцент (АРУ), Актыбинский региональный университет им. К.Жубанова, Актобе, Казахстан.

E-mail: tima2001@inbox.ru, <https://orcid.org/0000-0003-2028-9262>;

***Кайменова Турсынгул Сансызбаевна**² — магистр, старший преподаватель, Актыбинский региональный университет им. К.Жубанова, Актобе, Казахстан.

E-mail: kaynenova83@mail.ru, <https://orcid.org/0000-0001-8750-5703>;

Еркен Абылай Алмазулы² — магистрант, Актыбинский региональный университет им. К.Жубанова, Актобе, Казахстан.

E-mail: Abylai.erken@mail.ru, <https://orcid.org/0009-0001-4537-8942>;

Анотация. В современном мире электричество стало жизненно важным ресурсом, обеспечивающим функционирование практически всех аспектов нашей повседневной жизни. Однако, несмотря на стремительное развитие технологий и инфраструктуры, электросети все чаще сталкиваются с такими проблемами, как нехватка электроэнергии и перегрузки. Именно здесь на сцену выходит инновационная идея, которая может изменить способ удовлетворения наших потребностей в электроэнергии. Речь идет о концепции "автоматической малой генерации электроэнергии" - интеллектуальной системе, которая автоматически активирует небольшие электростанции, расположенные вблизи конечных потребителей, в случае дефицита электроэнергии в основной сети. Это не только способ повысить надежность электроснабжения, но и сделать его более стабильным и доступным.

Целью настоящего исследования является изучение и анализ потенциала малой энергетики для повышения устойчивости энергоснабжения, особенно в регионах с дефицитом электроэнергии, а также определение наилучших стратегий интеграции таких систем в существующую электросеть с минимальными потерями и максимальной эффективностью. Ситуация в отрасли становится все более сложной в связи с ростом малых генерирующих мощностей, которые меняют характер производства электроэнергии.

Ключевые слова: Электроэнергетика, электростанция, контент-анализ, статистический анализ, сравнительный анализ, релейная защита.